

Site Dumpers

NC
ENGINEERING







HT 18 10 HT 18 15 SW18 15

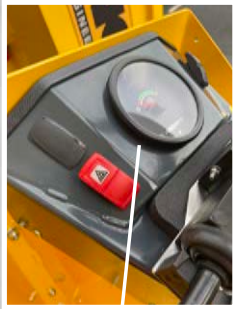

Clear dashboard layout

Twin lever control



Excellent service access



Tapered skip for maximum visibility

Twin lift cylinders



Four wheel drive Twinlock system



Super bright LED Lights





Protected hose lines

Fuse Box rated IP67

Unrivalled operator protection

Folding ROPS

Single pedal control

Fully adjustable seat with recoil safety belt

Heavy duty parallel linkage



Inclinometer

Joystick control

Twin Cylinder Power Swivel 180°

High Definition Step & Handrails



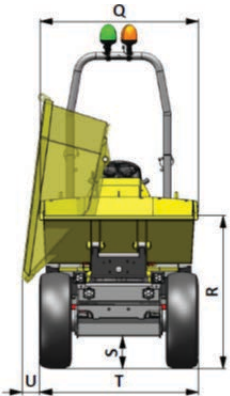
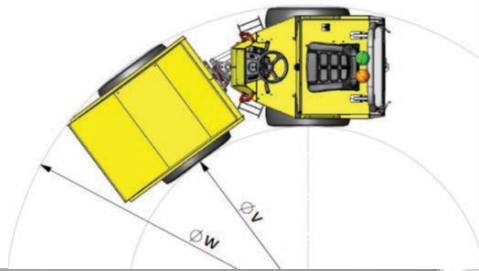
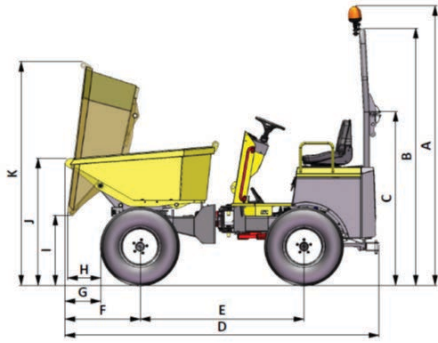
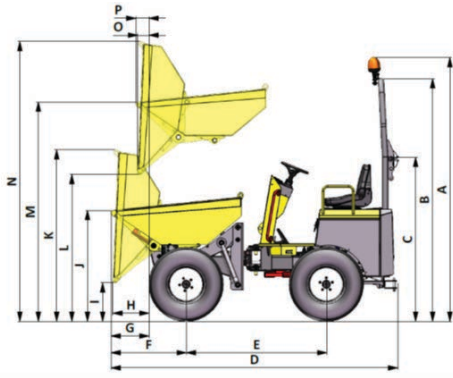

STATIC DIMENSIONS in mm

	HT1810	HT1815	SW1815
A	2841	2841	2841
B	2613	2613	2613
C	1766	1766	1766
D	3068	3112	3166
E	1503	1648	1648
F	806	705	760
G	406	305	360
H	387	343	333
I	413	417	713
J	1194	1224	1292
K	1847	1924	2273
L	1580	1555	N/A
M	2361	2362	N/A
N	3014	3061	N/A
O	121	141	N/A
P	141	103	N/A
Q	985	1267	1297
R	1184	1199	1266
S	271	271	271
T	1129	1300	1300
U	N/A	N/A	143
V	3433	3654	3654
W	5735	6405	6405
Tipping Angle°	82°	85°	78°

CAPACITY:	HT1810	HT1815*	SW1815*
Max. safe load:	1000 kg	1500kg	1500kg
Unladen Weight:	1310kg	1415kg	1380kg
Heaped:	510L	805L	813L
Struck:	407L	644L	628L
Water:	305L	428L	480L

ENGINE:

Kubota D1105
 Displacement: 1.1 L
 Max. power: 18.2kW/24.31bhp @ 3000 rpm
 Max. torque: 71.5Nm @ 2200 rpm
 Emissions to: (EU) 2016/1628 & Tier 4 US EPA & CARB

TRANSMISSION:

Hydrostatic automotive "Twin Lock"
 Permanent 4 wheel drive
 Acceleration by foot pedal
 Braking hydrostatic retardation

DRIVE CHARACTERISTICS:

Forward / Reverse 0-14 km/h (0-8.7 mph)
 0-11km/h* (0-7mph*)
 Steering angle: +/- 36.5°
 Turning Circle: 5.74m
 6.41m*
 Gradeability: 50%
 Tyres: 10.0 / 75 -15.3 (traction Profile)
 Steering: Priority load sensing centre pivot
 Working brakes: Hydrostatic retardation
 Park brake: Automatic in rear wheel motors

NOISE LEVELS:

LWA 99dB(A)
 LPA 81dB(A)

TANK CAPACITIES:

Fuel: 28L
 Hydraulic: 25L

SKIP:

Hydraulically operated tipping skip for increased performance
 Heavy duty fully welded skip
 Reinforced around the top for greater strength

ELECTRICAL:

Heavy duty H075 Battery: 12V, 550CCA, 60Ah
 Wiring harness in protective sleeving
 Auxiliary outputs
 Reversing alarm
 Flashing amber beacon

HYDRAULICS:

Automotive control hydrostatic pump
 Hydraulic test points fitted as standard
 Easy access return oil filter on top of tank

SEATING & CONTROLS:

Adjustable suspension seat
 Clear access across dumper
 Super bright instrument display
 Steel constructed centre console for extra leg protection
 Column mounted directional control lever
 Anti-slip floor
 Highlighted steps + handrails

SERVICE ACCESS:

Easy access for service maintenance
 Lockable hinged engine cover
 Battery mounted inside the engine bay

We reserve the right to change the above specification without prior notice.

Optional Extras

O = Option N/A = Not Available

Option	HT1810	HT1815	SW1815
Hardox Skip	NA	NA	O
Special Colour RAL (yellow parts only)	O	O	O
Green Seat Belt Light	O	O	O
Fixed Warning Triangle	NA	NA	NA
Folding Warning Triangle	O	O	O
Mirrors	O	O	O
Wheel Choc	O	O	O
Road Lights	O	O	O
Recovery Hitch	O	O	O
Scharmuller Hitch	O	O	O
7 pin towing socket (only available with road lights option)	O	O	O
7 pin towing socket for Scharmuller hitch (only available with road lights option)	O	O	O
Grass Pattern Tyres	O	O	O
Panolin Bio Oil	O	O	O
Telematics Tracking Device	O	O	O
Toolbox	O	O	O
Wheel Nut Indicators	O	O	O
Speed Decal	O	O	O
Parking Light Switch (only available with road lights option)	O	O	O
Weather Cover for Seat inc. storage box	O	O	O
Day Time Running Lights (only available with road lights option)	O	O	O
Guard on Rear of Skip	NA	NA	NA
Front Number Plate Mounting Bracket	NA	NA	O
Lockable Diesel Cap	O	O	O
Lock for Hydraulic tank	O	O	O
CESAR datatag system	O	O	O
First Service Filter kit	O	O	O
Inching pedal	NA	NA	NA
Spare Wheel Assembly	O	O	O
Side Marker lights on mudguards	NA	NA	NA
Narrow wheels & tyres	O	NA	NA
White Noise Reverse Alarm	O	O	O
Front Tow Bracket	NA	NA	NA
Rear Reflectors	O	O	O

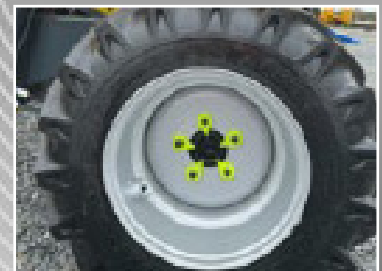

SW 30 19



Site mode speed limiter

Super bright LCD Display IP67 rated



Two stage start inhibitor safety system



Front & Rear Guarded lights

Front facing 150° wide angle camera

Hydraulic parking brake (SAHR) No in field adjustment required



High definition steps+handrails

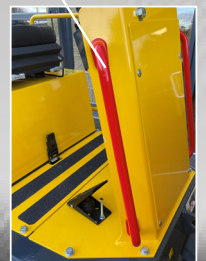
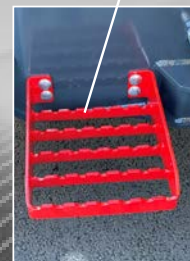

Service access via lockable bonnet



Integrated Toolbox



Protected IP67 rated 7" LCD Monitor

Sealed Fusebox IP67

Green beacon seat belt system (option)

180° Powerswivel bucket

Solid steel rear cover for maximum impact protection



Multi axis joystick control

Nitrotec coated pivot pins for extended life

Inclinometer



Fully adjustable suspension seat with recoil safety belt and document pouch

Super bright LED rear lights with sequential indicators

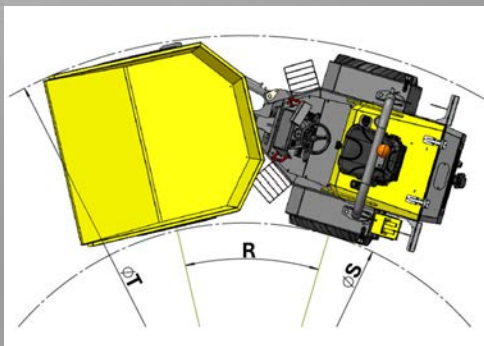
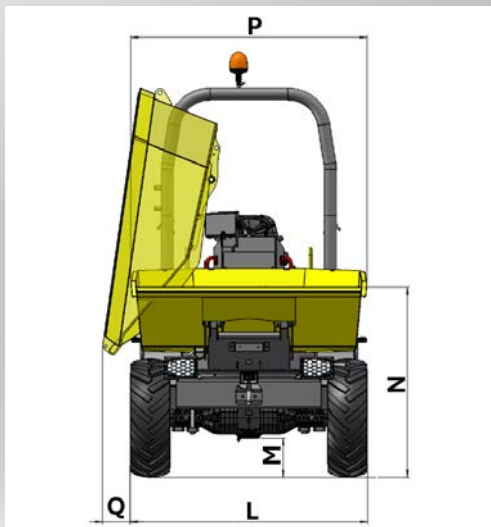
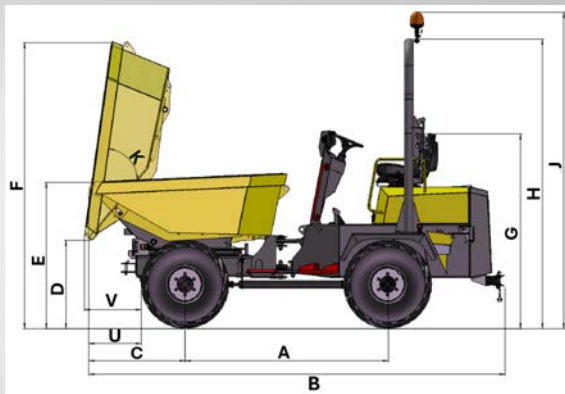

STATIC DIMENSIONS in mm

A	2000
B	4106
C	955
D	873
E	1436
F	2823
G	1914
H	2848
J	3112
L	1730
M	288
N	1385
P	1722
Q	186
S	5009
T	8700
U	522
V	558

SW30
19

CAPACITY:

Max. safe load: 3000kg
 Unladen Weight: 2430kg
 Heaped: 1663L
 Struck: 1242L
 Water: 910L

ENGINE:

Make: Kubota 3 Cyl water cooled
 Model: D1105
 Displacement: 1.1 L
 Max. power: 18.2kW/24.4bhp @ 3000 rpm
 Max. torque: 72Nm @ 2200 rpm
 Fuel: Diesel
 Emissions to: (EU) 2016/1628 & Tier 4 US EPA & CARB

TRANSMISSION:

Switchable twin mode hydrostatic CVT
 Permanent 4-wheel drive

DRIVE CHARACTERISTICS:

Forward / Reverse: 0-20 km/h / 0-12.5 mph
 Steering angle: +/- 33°
 Turning Circle: 8.7m
 Gradeability: 50%
 Tyres (Traction Profile): 11.5/80-15.3 12PR
 Steering: Priority load sensing hydrostatic centre pivot
 Working brakes: Multi-plate oil immersed discs mounted on front axle
 Park brake: Hand operated (SAHR) spring applied hydraulically released

NOISE LEVELS:

LWA: 101dB(A)
 LPA: 80dB(A)

TANK CAPACITIES:

Fuel: 40L
 Hydraulic: 34L

SKIP:

Hydraulically operated skip tipping to 77.5°
 Heavy duty fully welded skip with high tensile sides 6 mm base
 Reinforced with Domex steel around top for greater strength
 Operated by a multi axis joystick for increased performance

ELECTRICAL:

Battery: 075E 12V, 550CCA, 60Ah
 Wiring harness in protective sleeving with auxiliary outputs

HYDRAULICS:

Automotive control hydrostatic pump
 Hydraulic test points fitted as standard
 Easy access return oil filter on top of tank

SEATING & CONTROLS:

Adjustable suspension seat accessible from both sides
 Clear access across dumper
 High definition steps and handrails
 Super bright instrument display
 Steel constructed centre console for extra leg protection
 Column mounted directional control lever
 Anti-slip floor

SERVICE ACCESS:

Easy access for service/ maintenance
 Lockable hinged engine bay doors
 Battery mounted inside the engine bay

STANDARD EQUIPMENT:

Flashing amber beacon
 Reversing alarm
 Recovery hitch
 Forward facing camera c/w 7" LCD monitor
 Inclinometer

We reserve the right to change the above specification without prior notice.

Optional Extras

Base unit:

Hardox Skip
Special Colour RAL (yellow parts only)

Safety:

Green Light Seat belt warning System
Warning Triangle
Wheel Choc
Mirrors

Towing:

7 pin Towing Socket
Scharmuller Tow Hitch

Tyres:

Grass Pattern 11.5/80-15.3 14PR

Environment:

Panolin Bio in Lieu of HVLP 46

Security:

Cesar Datatag
Telematic Tracking

Maintenance:

Planned Service kits
Toolbox

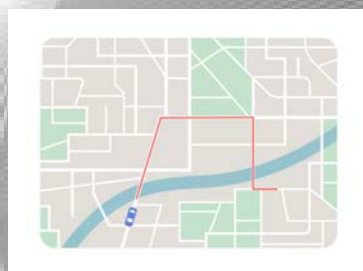
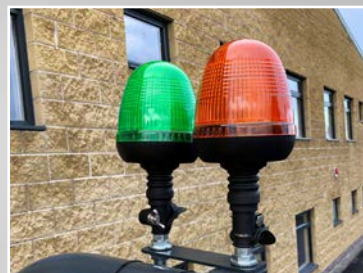

*based on data supplied by engine manufacturers rated speed

SW 55 50 SW 55 60



Site mode speed limiter

Super bright LCD Display IP67 rated



Two stage start inhibitor safety system

Folding ROPS, FOPS safety Frame



Guarded lights

Front facing 150° wide angle camera



Hydraulic parking brake (SAHR) No in field adjustment required



Highlighted Steps + Handrails

Nitrotec coated pivot pins for extended life





Service Access
Via Lockable
Bonnet



Protected IP67
rated 7" LCD
Monitor

15mm solid steel rear
cover for maximum
impact protection



Multi axis joystick

180°
Powerswivel

LED rear lights

Fully adjustable suspension
seat with recoil safety belt
and document pouch



Inclinometer



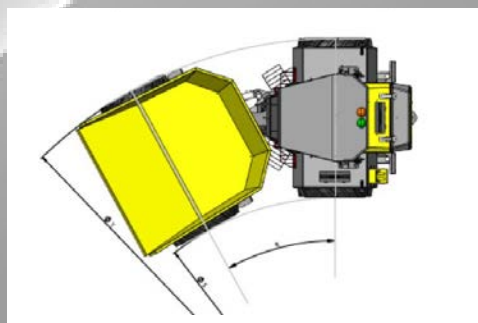
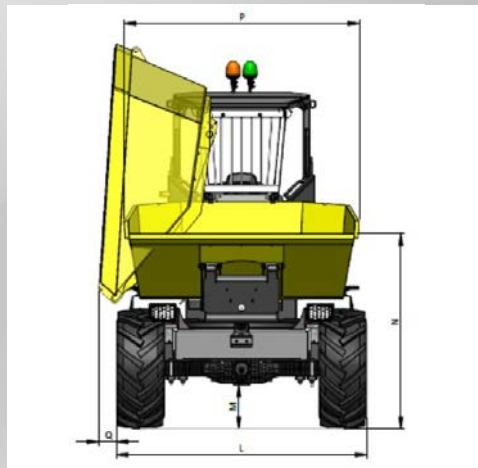
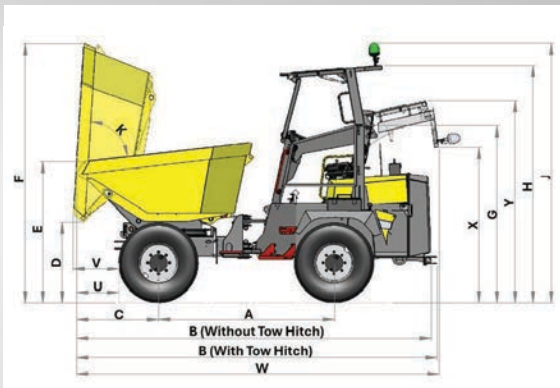

STATIC DIMENSIONS in mm		
	SW5550-C	SW5560-C
A	2210	2490
B	4530	4621
C	1030	974
D	993	1115
E	1767	1863
F	3230	3438
G	2214	2251
H	2967	3005
J	3248	3285
L	1815	2242
M	367	404
N	1667	1746
P	1920	2106
Q	292	156
S	5947	7452
T	9870	12000
U	529	434
V	565	493
W	4553	4638
X	1940	1940
Y	2529	2529

CAPACITY:	SW5550-C	SW5560-C
Max. safe load:	5000kg	6000kg
Unladen Weight:	3825kg	4200kg
Heaped:	2633L	3150L
Struck:	2110L	2444L
Water:	1368L	1650L

SW5550
SW5560

ENGINE:	
Make	Doosan 4 Cyl water cooled
Model	D24 DM02VB
Displacement:	2.4 L
Max. power:	55.4kW/74.3bhp @ 2600 rpm
Max. torque:	320Nm @ 1600 rpm
Fuel:	Diesel
Emissions to:	(EU) 2016/1628

TRANSMISSION:	
	Switchable twin mode hydrostatic CVT
	Permanent 4-wheel drive

DRIVE CHARACTERISTICS:		
Forward / Reverse	0-25 km/h	0-26 km/h
	0-15.5 mph	0-16.1 mph
Steering angle:	+/- 32°	+/- 29°
Turning Circle:	9.87m	12m
Gradeability:	50%	50%
Tyres:	12.5/80-18 16PR	405/70-20
Steering:	Priority load sensing hydrostatic centre pivot	
Working brakes:	Multi-plate oil immersed discs mounted on front axle	
Park brake:	Hand operated (SAHR) spring applied hydraulically released	

NOISE LEVELS:		
LWA	101dB(A)	101dB(A)
LPA	83dB(A)	85dB(A)

TANK CAPACITIES:		
Fuel:	56L	56L
Hydraulic:	54L	54L

SKIP:
Hydraulically operated skip tipping to 82°
Heavy duty fully welded skip with high tensile sides 8 mm base
Reinforced around top for greater strength
Operated by a multi axis joystick for increased performance

ELECTRICAL:
Super heavy duty 100SPPLA Battery: 12V, 700CCA, 74Ah
Wiring harness in protective sleeving with auxiliary outputs

HYDRAULICS:
Automotive control hydrostatic pump
Hydraulic test points fitted as standard
Easy access return oil filter on top of tank

SEATING & CONTROLS:
Adjustable suspension seat accessible from both sides
Clear access across dumper
High definition steps and handrails
Super bright warning lights on fully featured display instrument
Steel constructed centre console for extra leg protection
Column mounted directional control lever
Anti-slip floor

SERVICE ACCESS:
Easy access for service/ maintenance
Lockable hinged engine bay doors

STANDARD EQUIPMENT:
Road lighting
Forward facing camera c/w 7" LCD monitor
Flashing amber beacon
Reversing alarm
Recovery hitch
Folding ROPS, FOPS, safety frame
Inclinometer

Optional Extras

Base unit:

Hardox Skip
Special Colour RAL (yellow parts only)

Cabin:

Rops, Fops Cab Level 2
Air Conditioning
Screen Guard

Towing:

Scharmuller Tow Hitch
7 pin Towing Socket

Tyres:

Grass Pattern 405/70-20

Environment:

Panolin Bio Hydraulic Oil
in Lieu of HVLP 46 Hydraulic Oil

Security:

Cesar Datatag
Telematic Tracking

Additional Safety Options:

Bucket Guard
Radar
360° Camera
Green Light Seat belt warning System
Warning Triangle
Wheel Choc
Mirrors (Rear view attached to Roll Bar)

Maintenance:

Planned Service kits
Toolbox



Coming
Soon



*based on data supplied by engine manufacturers rated speed



NC

ENGINEERING

Rev 3 - July 2025



NC Engineering (Hamiltonsbawn) Ltd
2 Killyrudden Road
Hamiltonsbawn,
Co. Armagh
Northern Ireland
BT61 9SF
Tel: +44 (0) 28 38 871970
E-Mail: sales@nc-engineering.com
Web: www.nc-engineering.com



www.nc-engineering.com